



MODEL eRED

DOWNBLAST CENTRIFUGAL ROOF EXHAUSTER WITH ELECTRONICALLY COMMUTATED MOTOR



MODEL FEATURES

- Exhaust air up to 3,000 CFM in high static pressure applications up to 1.5" w.g.
- Attractive spun aluminum exterior
- Motor has 80% usable turndown vs. 30% on a PSC motor
- Direct drive units have low sound levels and quiet operation
- Non-overloading backward inclined wheel for efficiency at higher static pressures
- AMCA Air and Sound Licensed
- cULus 705 Listed

MODEL OVERVIEW

Model eRED fans are designed to exhaust air up to 3,000 CFM in high static pressure applications to 1.5". The spun aluminum exterior provides an attractive appearance. The non-overloading backward inclined wheel with its higher static pressure capability makes this unit suitable for either ducted or nonducted applications. Its roof mounting permits location near the area to be ventilated, allowing short duct runs and more efficient operation.

The eRED comes with S&P's electronically commutated motor (eMotor) which offers the energy efficiency of a DC motor with the ease of maintenance of DD motors. The eMotor provides the benefit of a fully controllable motor which can be controlled by a PC or building management system.

The eRED is ideally suited to solve ventilation challenges in multi-story buildings. When used with one of S&P's constant pressure controls (see control options on page 21) this fan model provides an energy efficient answer to venting dryers, bathrooms and kitchens in hotels, high rise buildings, institutional facilities and dormitories.

CONSTRUCTION FEATURES AND OPTIONS

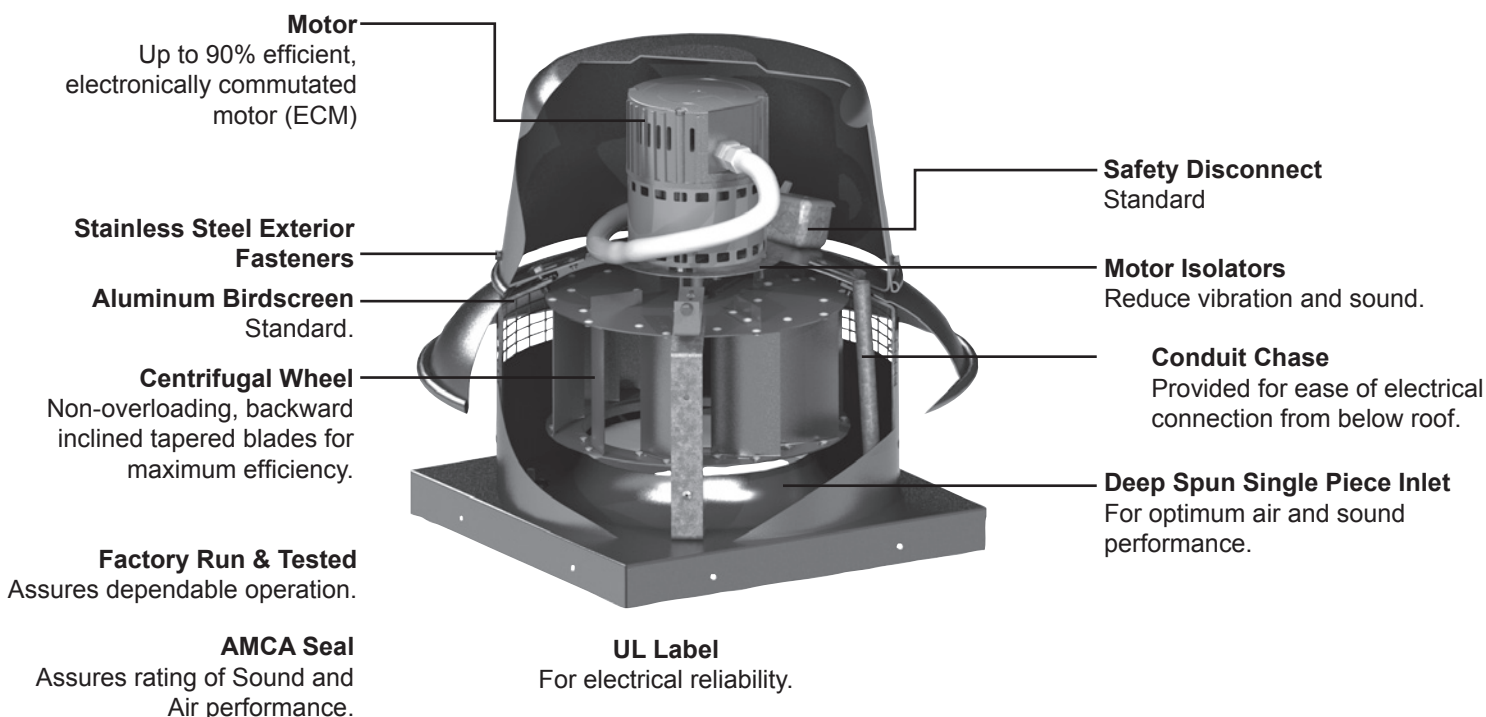

Industry best 5 year fan housing warranty, 1 year motor warranty

All specifications are subject to change without notice unless approved in submittal by Soler & Palau.



CONSTRUCTION/SPECIFICATION CHECKLIST

Housing

- Curb cap has integral deep spun inlet for efficient performance and prepunched mounting holes for ease of installation.
- Fan plate isolates motor compartment from contaminated exhaust air.
- Spun aluminum hood and skirt for weather protection and attractive appearance.
- Heavy-gauge motor support for rigidity and strength.
- Neoprene isolators for reduction of vibration and sound.
- Quick access to motor compartment for ease of maintenance.
- Conduit passage for easy electrical connection from below roof.
- Birdscreen included on standard models.

Wheel

- Backward inclined for efficiency at higher static pressure.
- Non-overloading for safe operation in ducted systems.
- Tapered blades for efficiency and quiet operation.
- Wheels constructed of noncorrosive aluminum.
- Statically and dynamically balanced for smooth operation.

Electronically Commutated Motors

- Brands are nationally recognized and locally serviced.
- Easy speed control by DC 0-10 V variation or EC style speed controller.
- Motor has motor mounted potentiometer with digital readout for easy speed adjustment.
- Can be controlled by a PC or building management system.
- Motor has 80% usable turndown vs. 30% on a PSC motor.
- Internal motor circuitry converts 115/230 V single phase AC power to DC voltage for increased efficiencies.
- All motors are rated for continuous duty.
- Motor is 115/230V and 50/60 Hz.
- Disconnect is standard.
- Motors ship mounted as standard.

AMCA Seal

- Assures rating of Air and Sound performance.

UL Label

- UL 705 Listing assures electrical reliability.



eMotor - Electronically Commutated Motor

S&P's eMotor is 115/230V and 50/60 Hz and is available in 1/4, 1/3 and 1/2 HP. This fully controllable motor offers both reliability and low maintenance in one of the most efficient motor fan combinations in the industry.

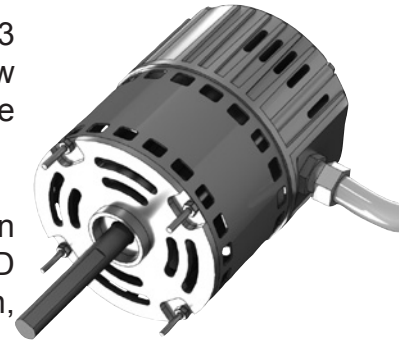

When used in S&P's eRED downblast fan, the eMotor is the ideal solution for a low cost, fully controlled ventilation system. This motor in the eRED can exhaust air volume up to 3,000 CFM, equal to that of a belt drive fan, with all the benefits and low maintenance of a direct drive fan.

Features and Advantages

- Easy speed control by DC 0-10 V variation or EC style speed controller
- Unit can be controlled by a PC or building management system
- Motor has 80% usable turndown vs. 30% on a PSC motor
- Internal motor circuitry converts 115/230 V single phase AC power to DC voltage for increased efficiencies.
- Motor is 115/230 V and 50/60 Hz
- cULus 705 Listing

Energy Savings = \$ Savings

eRED with 1/2 HP Motor - Continuous Ventilation

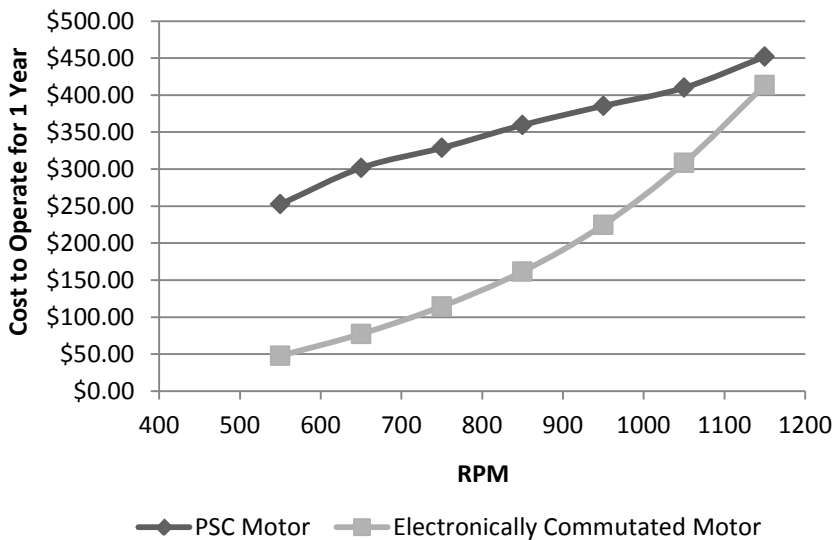

Cost to Operate Motors @ 650 RPM Continuous Ventilation

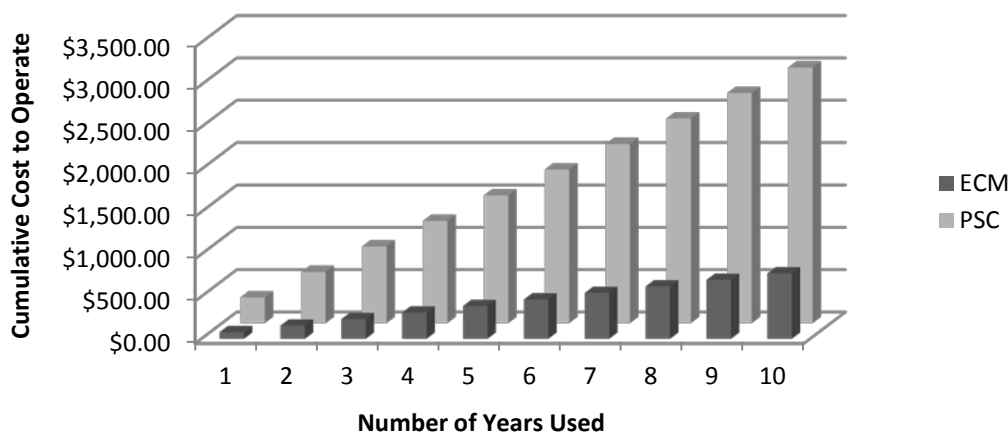



Constant Pressure Control Options with eRED

Constant Pressure Controls: For constant pressure control applications, the S&P constant pressure control package is available. This package includes the components that are needed to complete a demand-based exhaust ventilation system for kitchens, bathrooms, and/or clothes dryer exhaust in multi-story buildings.

S&P recognized that the programming procedure for many constant pressure controls can be challenging, so this package is the simplest system available. The control box can be easily installed in the field, either mounted on a curb or inside the building. The backlit LCD display and pressure transducer are pre-programmed to work together to increase or reduce the speed of the fan to accommodate for the actual demand.

Potentiometer with Factory Mount and Wire: Allows the operator to install the fan, set the exhaust flow to the desired rate and leave the fan fixed at a specific value. If optional mount and wire is chosen, the potentiometer will be mounted, wired and factory installed under the motor cover. Since exhaust fans are commonly oversized based upon assumptions, the ability to set the exhaust rate at the correct value in the field significantly reduces the amount of conditioned air that is unnecessarily removed, ensuring that the correct amount of air is removed in the most efficient manner.

Potentiometer Shipped Loose: If a variable rate that is manually changed by the operator from the occupied space is desired, the potentiometer is shipped loose and field installed in the appropriate accessible location. Simply rotating the dial will vary the speed of the fan from 20% to 100% full speed.



Control Box



Sensor



Potentiometer



OPTIONS/ACCESSORIES

Solid State Speed Control: S&P's solid state control is matched to the motor and blow wheel to allow continuous reduction in performance allowing adjustments of airflow for system balancing. CFM is reduced in direct proportion to motor speed reduction. Speed control available for 115 or 230 volt single phase. Exhauster performance can be controlled from the ventilated area.



Roof Curb: Prefabricated heavy-gauge galvanized steel welded construction clip lock, 14" high with 1-1/2" wood nailer. Assures perfect fit of exhauster to roof curb. Options include burglar bars, single and double pitch construction, and additional curb heights. Welded & custom curbs available.

Sound Curb: Option of thermal acoustical lining or a complete maximum sound attenuating baffle system. Provision for mounting damper is available. Contact factory for information regarding effect on exhauster air performance and sound level.

Motor Operated Aluminum Damper: Motor operated for positive closure against backdraft.



Automatic Damper: Automatic aluminum damper for ease in installation and effective backdraft protection.

Companion Gravity Units: Model RCX-II comes in a wide range of sizes and air capacities to provide relief or intake air to the system. Curbs and dampers are available to fit all sizes. Spun aluminum hoods provide a pleasing appearance, complementing the Model eRED exhauster.

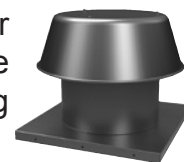

Curb Hinge Arrangement: The curb hinge arrangement provides easy access to the exhaust fan, backdraft damper, and duct for servicing and cleaning.

Special Coatings: Powered roof exhausters often require special coatings for protective and decorative purposes. Available coatings include: Epoxy, Synthetic Resin, and Heresite (air-dried phenolic). Contact your Soler & Palau representative or the factory for more information on available coatings and colors.



PERFORMANCE/DIMENSIONS

Model eRED6

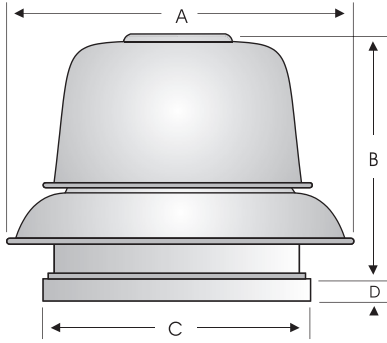

Damper		Roof Opening	Curb O.D.	A	B	C	D	Average Ship Wt. Lbs.
I.D.	O.D.							
11	11	11-3/4	14-3/4	21-3/4	12	16-1/2	1-3/4	50

RPM	CFM/BHP @ Static Pressure/Sones					
	0	0.125	0.25	0.375	0.5	0.625
850	190 0.01/1.5	-	-	-	-	-
900	202 0.01/1.9	95 0.01/1.2	-	-	-	-
950	213 0.01/2.2	115 0.01/1.5	-	-	-	-
1000	224 0.01/2.4	133 0.01/1.8	-	-	-	-
1050	235 0.01/2.7	150 0.01/2.1	-	-	-	-
1100	246 0.01/3	167 0.01/2.4	41 0.01/1.8	-	-	-
1150	257 0.01/3.2	182 0.01/2.7	73 0.01/2.2	-	-	-
1200	269 0.01/3.5	197 0.01/3	100 0.01/2.5	-	-	-
1250	280 0.02/3.8	211 0.02/3.3	124 0.02/2.9	-	-	-
1300	291 0.02/4.1	226 0.02/3.7	146 0.02/3.3	-	-	-
1350	302 0.02/4.5	239 0.02/4	165 0.02/3.7	52 0.02/3.2	-	-
1400	313 0.02/4.8	253 0.02/4.4	184 0.02/4.1	84 0.02/3.6	-	-
1450	325 0.03/5.2	266 0.03/4.8	201 0.03/4.4	113 0.02/4	-	-
1500	336 0.03/5.6	280 0.03/5.1	218 0.03/4.8	138 0.03/4.4	-	-
1550	347 0.03/6.1	293 0.03/5.5	234 0.03/5.2	161 0.03/4.8	54 0.02/4.4	-
1600	358 0.04/6.5	306 0.04/5.9	249 0.03/5.6	182 0.03/5.3	87 0.03/4.9	-
1650	369 0.04/7	319 0.04/6.4	265 0.04/6.1	201 0.04/5.8	117 0.03/5.4	-
1700	381 0.04/7.4	331 0.04/6.9	279 0.04/6.6	220 0.04/6.3	143 0.04/5.9	-
1750	392 0.05/7.9	344 0.05/7.5	294 0.05/7.1	237 0.04/6.8	168 0.04/6.4	72 0.04/6

Performance certified is for installation type A-free inlet, free outlet.

Performance ratings include the effects of birdscreen.

The sound ratings shown are loudness values in fan sones @ 5' (1.5m) in a hemispherical free field calculated per AMCA Standard 301. Values shown are for Installation Type A-free inlet hemispherical sone levels.

Speed (RPM) shown is nominal. Performance is based on actual speed of test.



S&P, Div. of Soler & Palau Ventilation Group, certifies that the Models eRED shown herein are licensed to bear the AMCA Seal. The ratings shown are based on test and procedures performed in accordance with AMCA Publication 211 and AMCA Publication 311 and comply with the requirement of the AMCA Certified Ratings Program.





MODEL eRED

DOWNBLAST CENTRIFUGAL ROOF EXHAUSTER WITH ELECTRONICALLY COMMUTATED MOTOR



Models eRED8

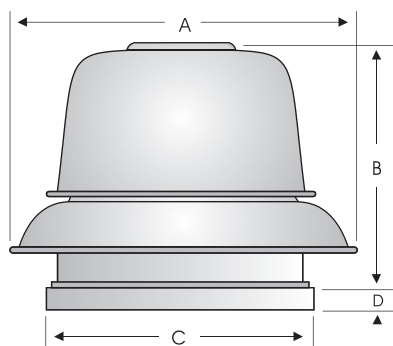

Damper		Roof Opening	Curb O.D.	A	B	C	D	Average Ship Wt. Lbs.
I.D.	O.D.							
11	11	11-3/4	14-3/4	21-3/4	13-1/2	16-1/2	1-3/4	50

RPM	CFM/BHP @ Static Pressure/Sones							
	0	0.125	0.25	0.375	0.5	0.625	0.75	1
600	342 0.01/1.3	103 0.01/0.4	-	-	-	-	-	-
650	371 0.01/1.7	175 0.01/0.6	-	-	-	-	-	-
700	399 0.01/2.1	229 0.02/1	-	-	-	-	-	-
750	428 0.02/2.5	275 0.02/1.3	-	-	-	-	-	-
800	456 0.02/2.9	317 0.02/1.8	-	-	-	-	-	-
850	485 0.03/3.4	356 0.03/2.3	148 0.02/1.7	-	-	-	-	-
900	514 0.03/3.9	394 0.03/2.7	224 0.03/2.1	-	-	-	-	-
950	542 0.04/4.3	430 0.04/3.2	283 0.04/2.5	-	-	-	-	-
1000	571 0.04/4.7	465 0.05/3.6	334 0.05/2.9	91 0.02/2.5	-	-	-	-
1050	599 0.05/5.1	500 0.05/4.1	380 0.05/3.2	197 0.04/2.9	-	-	-	-
1100	628 0.06/5.5	533 0.06/4.6	423 0.06/3.7	271 0.05/3.3	-	-	-	-
1150	656 0.07/6	566 0.07/5	463 0.07/4.2	331 0.07/3.7	92 0.03/3.4	-	-	-
1200	685 0.07/6.4	599 0.08/5.5	503 0.08/4.7	384 0.08/4.1	206 0.05/3.8	-	-	-
1250	713 0.08/6.8	631 0.09/6	540 0.09/5.2	432 0.09/4.5	286 0.07/4.2	-	-	-
1300	742 0.09/7.3	663 0.1/6.5	577 0.1/5.7	477 0.1/5	350 0.09/4.6	141 0.05/4.3	-	-
1350	770 0.11/7.8	695 0.11/7	613 0.12/6.2	520 0.12/5.5	407 0.11/5.1	245 0.08/4.8	-	-
1400	799 0.12/8.4	726 0.12/7.5	648 0.13/6.8	561 0.13/6.1	458 0.12/5.6	323 0.1/5.3	87 0.05/5	-
1450	827 0.13/8.9	757 0.14/8.1	683 0.14/7.3	600 0.14/6.7	506 0.14/6.1	388 0.13/5.8	214 0.09/5.5	-
1500	856 0.15/9.4	788 0.15/8.6	717 0.16/7.9	639 0.16/7.2	550 0.16/6.6	445 0.15/6.3	304 0.12/6	-
1550	884 0.16/10	819 0.17/9.2	750 0.17/8.5	676 0.18/7.8	593 0.17/7.2	497 0.17/6.8	376 0.15/6.5	-
1600	913 0.18/10.6	850 0.18/9.8	784 0.19/9	712 0.19/8.4	634 0.19/7.8	545 0.19/7.3	439 0.17/7	-
1650	941 0.19/11.3	880 0.2/10.5	816 0.21/9.7	748 0.21/9.1	674 0.21/8.4	591 0.21/7.9	495 0.2/7.6	193 0.11/7.1
1700	970 0.21/12	911 0.22/11.1	849 0.23/10.4	784 0.23/9.7	713 0.23/9.1	635 0.23/8.5	546 0.22/8.1	297 0.16/7.7
1750	998 0.23/12.7	941 0.24/11.9	881 0.25/11	818 0.25/10.3	751 0.25/9.7	677 0.25/9.1	595 0.24/8.7	378 0.2/8.2



S&P, Div. of Soler & Palau Ventilation Group, certifies that the Models eRED shown herein are licensed to bear the AMCA Seal. The ratings shown are based on test and procedures performed in accordance with AMCA Publication 211 and AMCA Publication 311 and comply with the requirement of the AMCA Certified Ratings Program.



Performance certified is for installation type A-free inlet, free outlet. Performance ratings include the effects of birdscreen. The sound ratings shown are loudness values in fan sones @ 5' (1.5m) in a hemispherical free field calculated per AMCA Standard 301. Values shown are for Installation Type A-free inlet hemispherical sone levels. Speed (RPM) shown is nominal. Performance is based on actual speed of test.



MODEL eRED

DOWNBLAST CENTRIFUGAL ROOF EXHAUSTER WITH ELECTRONICALLY COMMUTATED MOTOR



Models eRED10

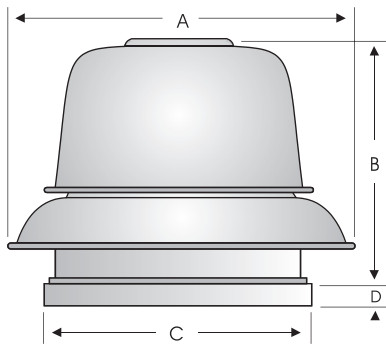

Damper		Roof Opening	Curb O.D.	A	B	C	D	Average Ship Wt. Lbs.
I.D.	O.D.							
11	11	11-3/4	14-3/4	21-3/4	17-1/4	16-1/2	1-3/4	50

RPM	CFM/BHP @ Static Pressure/Sones							
	0	0.125	0.25	0.375	0.5	0.625	0.75	1
550	488 0.01/1.5	59 0.01/0.6	-	-	-	-	-	-
600	533 0.01/1.9	220 0.01/0.9	-	-	-	-	-	-
650	577 0.02/2.3	312 0.02/1.4	-	-	-	-	-	-
700	621 0.02/2.8	386 0.02/1.8	-	-	-	-	-	-
750	666 0.02/3.3	452 0.02/2.3	-	-	-	-	-	-
800	710 0.03/3.8	513 0.03/2.8	182 0.03/2.2	-	-	-	-	-
850	755 0.04/4.3	571 0.04/3.3	315 0.04/2.6	-	-	-	-	-
900	799 0.04/4.8	627 0.04/3.8	409 0.04/3.1	-	-	-	-	-
950	843 0.05/5.3	682 0.05/4.3	488 0.05/3.6	86 0.03/3.1	-	-	-	-
1000	888 0.06/5.8	735 0.06/4.9	559 0.06/4.2	286 0.06/3.6	-	-	-	-
1050	932 0.07/6.3	787 0.07/5.5	625 0.07/4.7	404 0.07/4.1	-	-	-	-
1100	977 0.08/6.9	839 0.08/6.2	688 0.08/5.4	497 0.08/4.7	117 0.05/4.1	-	-	-
1150	1021 0.09/7.5	889 0.09/6.8	748 0.09/6.1	577 0.09/5.4	317 0.09/4.7	-	-	-
1200	1065 0.1/8.1	940 0.1/7.4	806 0.1/6.8	651 0.1/6	441 0.1/5.3	-	-	-
1250	1110 0.11/8.8	989 0.11/8.1	862 0.11/7.5	719 0.11/6.8	539 0.11/6	231 0.1/5.4	-	-
1300	1154 0.13/9.5	1038 0.13/8.8	917 0.13/8.2	783 0.13/7.5	623 0.13/6.8	394 0.13/6.1	-	-
1350	1198 0.14/10.2	1087 0.14/9.6	971 0.14/8.9	846 0.14/8.3	700 0.14/7.5	511 0.14/6.8	159 0.1/6.2	-
1400	1243 0.16/11	1136 0.16/10.4	1025 0.16/9.7	906 0.16/9.1	771 0.16/8.3	607 0.16/7.6	363 0.15/6.9	-
1450	1287 0.18/11.8	1184 0.18/11.2	1077 0.18/10.5	964 0.18/9.9	839 0.18/9.2	691 0.18/8.4	496 0.18/7.7	-
1500	1332 0.2/12.7	1232 0.2/12	1129 0.2/11.4	1021 0.2/10.8	903 0.2/10	769 0.2/9.2	602 0.2/8.5	-
1550	1376 0.22/13.2	1279 0.22/12.6	1180 0.22/12	1077 0.22/11.4	966 0.22/10.8	841 0.22/9.9	693 0.22/9.1	132 0.12/7.8
1600	1420 0.24/13.8	1327 0.24/13.2	1231 0.24/12.6	1132 0.24/12	1026 0.24/11.5	910 0.24/10.6	776 0.24/9.9	364 0.22/8.5
1650	1465 0.26/14.5	1374 0.26/13.8	1282 0.26/13.2	1186 0.26/12.7	1085 0.26/12.1	975 0.26/11.4	852 0.26/10.6	513 0.26/9.2
1700	1509 0.28/15.2	1421 0.29/14.5	1332 0.29/13.9	1239 0.29/13.3	1143 0.29/12.8	1039 0.29/12.1	924 0.29/11.3	630 0.29/9.9
1750	1554 0.31/15.8	1468 0.31/15.2	1381 0.31/14.6	1292 0.31/14	1199 0.31/13.4	1100 0.31/12.9	993 0.31/12.1	729 0.32/10.7



S&P, Div. of Soler & Palau Ventilation Group, certifies that the Models eRED shown herein are licensed to bear the AMCA Seal. The ratings shown are based on test and procedures performed in accordance with AMCA Publication 211 and AMCA Publication 311 and comply with the requirement of the AMCA Certified Ratings Program.



Performance certified is for installation type A-free inlet, free outlet. Performance ratings include the effects of birdscreen. The sound ratings shown are loudness values in fan sones @ 5' (1.5m) in a hemispherical free field calculated per AMCA Standard 301. Values shown are for Installation Type A-free inlet hemispherical sone levels. Speed (RPM) shown is nominal. Performance is based on actual speed of test.



MODEL eRED

DOWNBLAST CENTRIFUGAL ROOF EXHAUSTER WITH ELECTRONICALLY COMMUTATED MOTOR



Models eRED12

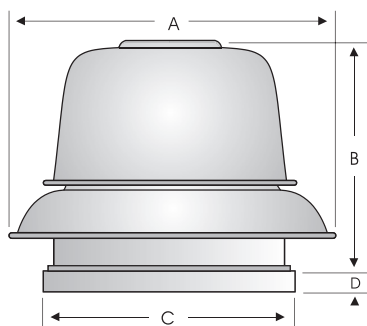

Damper		Roof Opening	Curb O.D.	A	B	C	D	Average Ship Wt. Lbs.
I.D.	O.D.							
18	18	19-1/4	22-1/4	33-1/8	23-1/2	24	2	124

RPM	CFM/BHP @ Static Pressure/Sones									
	0	0.125	0.25	0.375	0.5	0.625	0.75	1	1.25	1.5
500	751 0.01/2	248 0.01/1.1	-	-	-	-	-	-	-	-
550	826 0.02/2.5	368 0.02/1.6	-	-	-	-	-	-	-	-
600	901 0.02/3.1	466 0.02/2.2	-	-	-	-	-	-	-	-
650	976 0.03/3.7	556 0.03/2.7	162 0.03/2.5	-	-	-	-	-	-	-
700	1051 0.04/4.4	641 0.04/3.3	331 0.04/3	-	-	-	-	-	-	-
750	1126 0.04/5	722 0.05/4	459 0.05/3.5	-	-	-	-	-	-	-
800	1201 0.05/5.7	801 0.06/4.6	566 0.06/4.1	214 0.05/4	-	-	-	-	-	-
850	1276 0.06/6.3	879 0.07/5.3	662 0.07/4.7	385 0.07/4.4	-	-	-	-	-	-
900	1351 0.08/7	956 0.08/5.9	753 0.08/5.3	518 0.08/5	151 0.07/5	-	-	-	-	-
950	1426 0.09/7.6	1032 0.09/6.6	839 0.1/6	631 0.1/5.6	343 0.09/5.5	-	-	-	-	-
1000	1501 0.1/8.3	1107 0.11/7.3	922 0.11/6.6	733 0.11/6.3	497 0.11/6.1	-	-	-	-	-
1050	1576 0.12/9	1182 0.13/8	1004 0.13/7.3	828 0.13/7	624 0.13/6.7	341 0.12/6.7	-	-	-	-
1100	1651 0.14/9.8	1256 0.14/8.8	1084 0.15/8	918 0.15/7.6	735 0.15/7.4	504 0.14/7.2	176 0.13/7.2	-	-	-
1150	1726 0.16/10.6	1330 0.16/9.7	1162 0.17/8.9	1004 0.17/8.4	837 0.17/8.1	639 0.17/7.9	372 0.16/7.9	-	-	-
1200	1801 0.18/11.4	1403 0.19/10.6	1240 0.19/9.7	1089 0.19/9.2	933 0.19/8.9	757 0.19/8.6	538 0.18/8.5	-	-	-
1250	1876 0.2/12.4	1477 0.21/11.4	1317 0.21/10.7	1171 0.22/10	1024 0.22/9.7	864 0.22/9.4	676 0.21/9.3	123 0.18/9.3	-	-
1300	1952 0.23/13.3	1550 0.23/12.4	1393 0.24/11.6	1252 0.24/10.9	1112 0.25/10.6	964 0.25/10.3	796 0.24/10	324 0.22/10	-	-
1350	2027 0.25/14.3	1623 0.26/13.4	1469 0.27/12.6	1332 0.27/11.8	1197 0.28/11.4	1058 0.28/11.1	906 0.27/10.9	508 0.26/10.8	-	-
1400	2102 0.28/15.3	1695 0.29/14.4	1544 0.3/13.6	1410 0.3/12.9	1281 0.31/12.3	1149 0.31/12.1	1008 0.31/11.8	663 0.29/11.5	147 0.26/11.5	-
1450	2177 0.32/16.4	1768 0.32/15.4	1619 0.33/14.5	1488 0.34/13.9	1363 0.34/13.3	1237 0.34/13	1105 0.34/12.8	797 0.33/12.4	348 0.3/12.4	-
1500	2252 0.35/17.4	1840 0.36/16.5	1694 0.36/15.6	1566 0.37/14.9	1444 0.37/14.3	1323 0.38/13.9	1198 0.38/13.7	917 0.37/13.3	536 0.35/13.2	-
1550	2327 0.39/18.3	1912 0.39/17.4	1768 0.4/16.5	1642 0.41/15.8	1524 0.41/15.1	1407 0.42/14.7	1288 0.42/14.5	1028 0.41/14.1	697 0.4/13.9	226 0.36/13.9
1600	2402 0.42/19.2	1984 0.43/18.3	1842 0.44/17.4	1718 0.45/16.7	1603 0.45/16.1	1489 0.46/15.5	1375 0.46/15.3	1131 0.46/14.9	837 0.44/14.6	427 0.41/14.6
1650	2477 0.47/20	2056 0.47/19.2	1916 0.48/18.3	1794 0.49/17.6	1681 0.49/17	1571 0.5/16.4	1461 0.5/16.1	1230 0.5/15.7	962 0.49/15.3	610 0.47/15.3
1700	2552 0.51/21	2128 0.52/20	1989 0.53/19.3	1869 0.53/18.5	1758 0.54/17.9	1651 0.54/17.3	1545 0.55/16.9	1324 0.55/16.5	1077 0.54/16.1	769 0.52/16



S&P, Div. of Soler & Palau Ventilation Group, certifies that the Models eRED shown herein are licensed to bear the AMCA Seal. The ratings shown are based on test and procedures performed in accordance with AMCA Publication 211 and AMCA Publication 311 and comply with the requirement of the AMCA Certified Ratings Program.



Performance certified is for installation type A-free inlet, free outlet. Performance ratings include the effects of birdscreen. The sound ratings shown are loudness values in fan sones @ 5' (1.5m) in a hemispherical free field calculated per AMCA Standard 301. Values shown are for Installation Type A-free inlet hemispherical sone levels. Speed (RPM) shown is nominal. Performance is based on actual speed of test.



MODEL eRED

DOWNBLAST CENTRIFUGAL ROOF EXHAUSTER WITH ELECTRONICALLY COMMUTATED MOTOR



Models eRED15

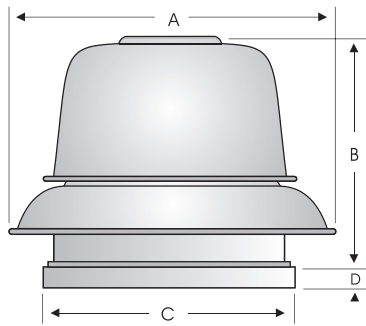

Damper		Roof Opening	Curb O.D.	A	B	C	D	Average Ship Wt. Lbs.
I.D.	O.D.							
18	18	19-1/4	22-1/4	33-1/8	23-1/2	24	2	124

RPM	CFM/BHP @ Static Pressure/Sones						
	0	0.125	0.25	0.375	0.5	0.625	0.75
400	1046 0.02/1.9	255 0.03/0.6	-	-	-	-	-
450	1177 0.03/2.7	524 0.03/1.3	-	-	-	-	-
500	1308 0.04/3.4	738 0.04/2.1	-	-	-	-	-
550	1439 0.05/4.2	931 0.05/2.9	245 0.09/2	-	-	-	-
600	1569 0.07/5	1110 0.07/3.6	562 0.08/2.8	-	-	-	-
650	1700 0.09/5.8	1281 0.09/4.5	803 0.09/3.6	-	-	-	-
700	1831 0.11/6.7	1445 0.11/5.4	1015 0.11/4.5	489 0.14/3.7	-	-	-
750	1962 0.13/7.6	1605 0.13/6.4	1212 0.13/5.4	766 0.14/4.6	-	-	-
800	2093 0.16/8.5	1760 0.16/7.3	1398 0.16/6.4	1000 0.16/5.6	511 0.22/4.8	-	-
850	2223 0.19/9.5	1912 0.19/8.4	1575 0.19/7.3	1213 0.19/6.6	802 0.21/5.9	187 0.44/5.2	-
900	2354 0.23/10.6	2062 0.23/9.4	1747 0.23/8.4	1413 0.22/7.7	1047 0.23/6.9	607 0.31/6.2	-
950	2485 0.27/11.8	2210 0.27/10.6	1914 0.27/9.6	1602 0.26/8.7	1269 0.27/8	895 0.37/7.3	401 0.47/6.6
1000	2616 0.31/13	2356 0.31/11.8	2077 0.31/10.7	1785 0.31/9.9	1476 0.31/9.2	1142 0.32/8.4	753 0.47/7.7
1050	2746 0.36/14.2	2500 0.36/13.1	2236 0.36/12	1961 0.36/11.1	1673 0.36/10.4	1367 0.36/9.6	1029 0.4/8.9
1100	2877 0.42/15.5	2643 0.42/14.3	2392 0.42/13.3	2132 0.41/12.4	1862 0.41/11.6	1577 0.41/10.9	1272 0.43/10.2
1150	3008 0.48/16.8	2786 0.47/15.7	2546 0.47/14.7	2299 0.47/13.7	2044 0.47/12.9	1778 0.47/12.3	1496 0.47/11.5

Performance certified is for installation type A-free inlet, free outlet. Performance ratings include the effects of birdscreen. The sound ratings shown are loudness values in fan sones @ 5' (1.5m) in a hemispherical free field calculated per AMCA Standard 301. Values shown are for Installation Type A-free inlet hemispherical sone levels. Speed (RPM) shown is nominal. Performance is based on actual speed of test.



S&P, Div. of Soler & Palau Ventilation Group, certifies that the Models eRED shown herein are licensed to bear the AMCA Seal. The ratings shown are based on test and procedures performed in accordance with AMCA Publication 211 and AMCA Publication 311 and comply with the requirement of the AMCA Certified Ratings Program.

